



P.O. Box 247 • Lansdale, PA 19446-0247
 Tel: 215-699-8700 • Fax: 215-699-0370
 Toll-Free Tel: 1-888-3NEPTUNE (1-888-363-7886)
 Toll-Free Fax: 1-800-255-4017
 Web Site: <http://www.neptune1.com>
 E-mail: pump@neptune1.com

Important Note:

These instructions describe Neptune Models VTF and DBF By-Pass Feeders with or without a filter bag plus Model DBFC By-Pass Feeders with Cartridge Filter and Models FTF and FTF-DB Filter Feeders which use a bag inside the basket filter.

Note carefully the flow arrow shown for each type of feeder. The flow in the standard by-pass feeder must be "upward" if a filter bag kit is to be used. The flow on the by-pass feeder with a cartridge filter is "downward." The filter feeder with bag and basket filter requires "downward" flow.

INSTALLATION & OPERATION INSTRUCTIONS – ALL MODELS

1. Pipe feeder to cause pressure drop across inlet and outlet resulting in flow through feeder.
2. Provide isolation and drain valves for servicing and draining.
3. Use with hot or cold water only. DO NOT USE FOR STEAM (300 psi @ 200°F max.).
4. Be certain gasket is positioned in groove under cap before replacing cap. (Replace gasket if cap does not seal by hand pressure.) Cap should seal with hand tightening pressure only. Do not strike cap with any tool to seal or unseal.
5. Open valves slowly when returning service.
6. **CAUTION! DO NOT OPEN UNDER PRESSURE – close isolation valves and bleed off pressure before opening.**
7. **CAUTION! CONTENTS MAY BE HOT.**
8. CONSULT YOUR CHEMICAL SUPPLIER FOR THE PROPER USE OF THIS TANK WITH THE CHEMICAL.
9. DO NOT COMBINE CHEMICALS IN THIS DISPENSING DEVICE – without specific instructions from your chemical supplier. READ AND FOLLOW LABEL DIRECTIONS FOR THE CHEMICAL IN USE.

Standard By-Pass Feeder MODELS VTF & DBF

Refer to installation and operation instructions above.

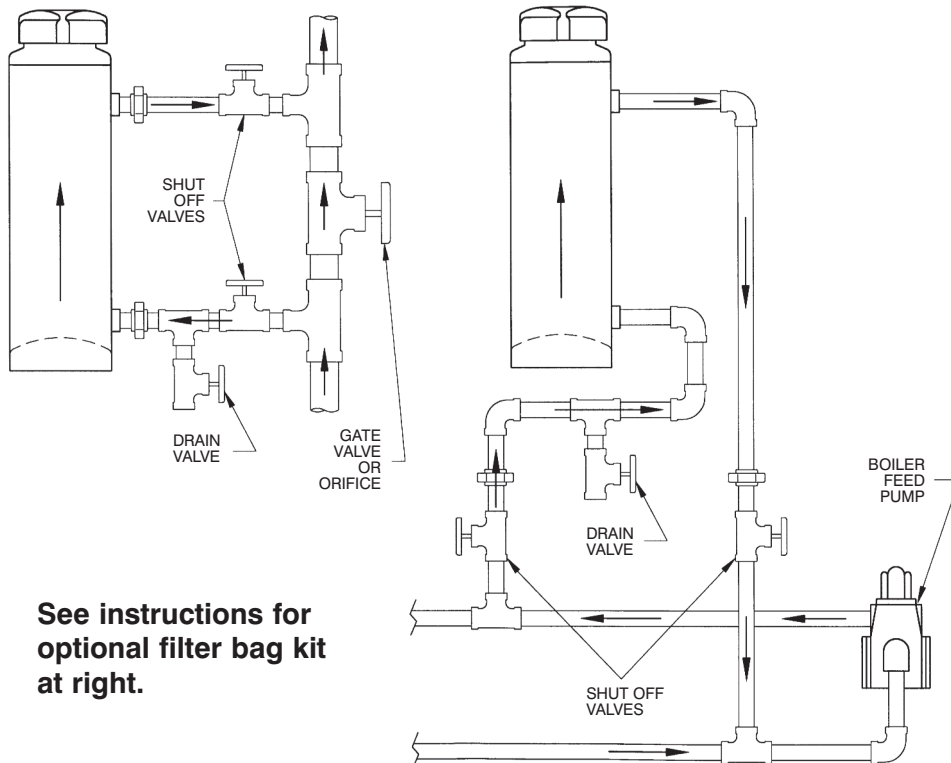

See instructions for optional filter bag kit at right.

Filter Bag Kit Option (FOR MODELS VTF & DBF ONLY)

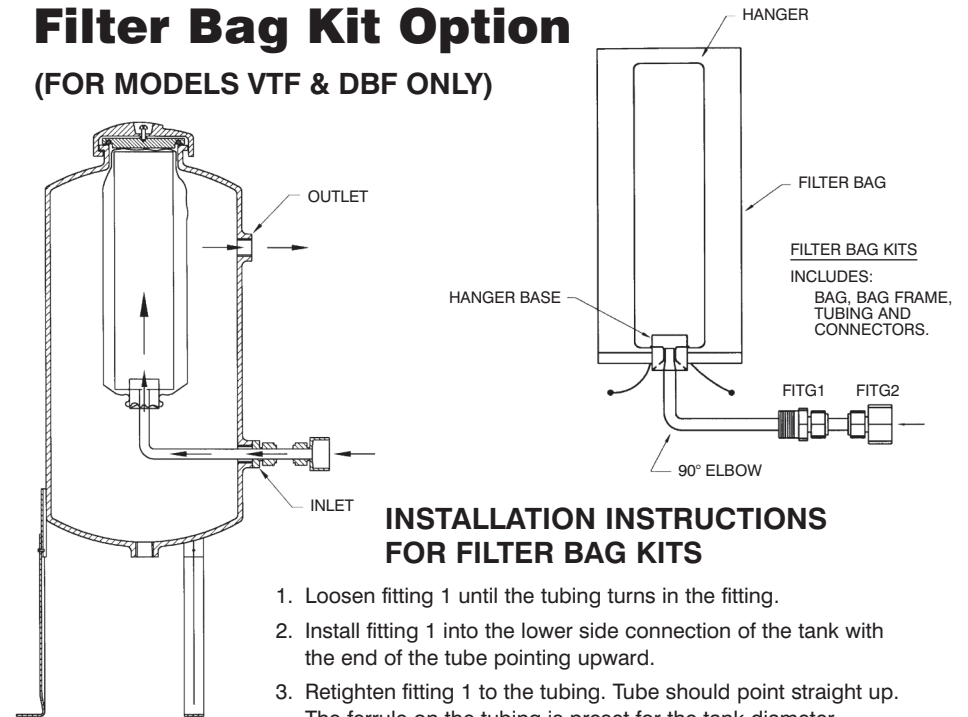

INSTALLATION INSTRUCTIONS FOR FILTER BAG KITS

1. Loosen fitting 1 until the tubing turns in the fitting.
2. Install fitting 1 into the lower side connection of the tank with the end of the tube pointing upward.
3. Retighten fitting 1 to the tubing. Tube should point straight up. The ferrule on the tubing is preset for the tank diameter.
4. Place bag over the hanger wire. Pull the drawstring closed and tie tightly so the bag gathers around the hanger base with the opening of the hanger base protruding from the bag.
5. Insert the bag and hanger base into the tank with the opening of the hanger base pointing downward. The hanger base should engage the tube which is pointing upward and the tubing should fit into the hanger base until the tubing rests against the edges of the wire which protrude into the center of the hanger base.
6. The cap will keep downward force on the wire, keeping the assembly in place.

Filter Feeder

MODELS FTF & FTF-DB

Refer to installation and operation instructions on other side.

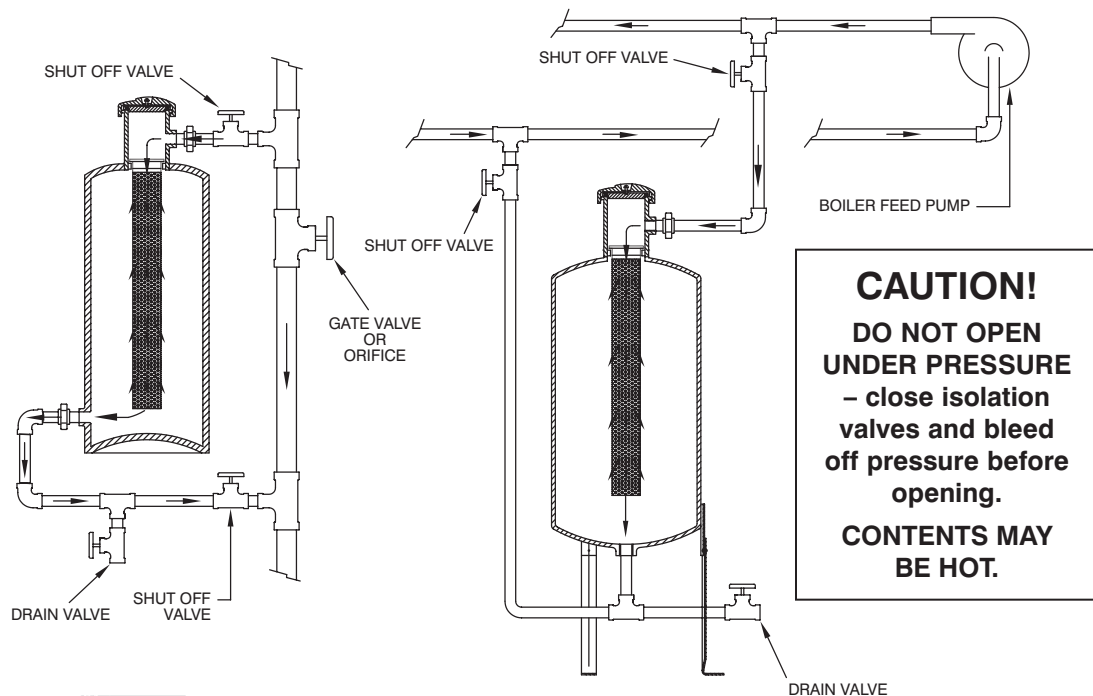

CAUTION!
DO NOT OPEN
UNDER PRESSURE
- close isolation
valves and bleed
off pressure before
opening.
CONTENTS MAY
BE HOT.

By-Pass Feeder with Cartridge Filter

MODEL DBFC

Refer to installation and operation instructions
on other side. Maximum flow 6 GPM.

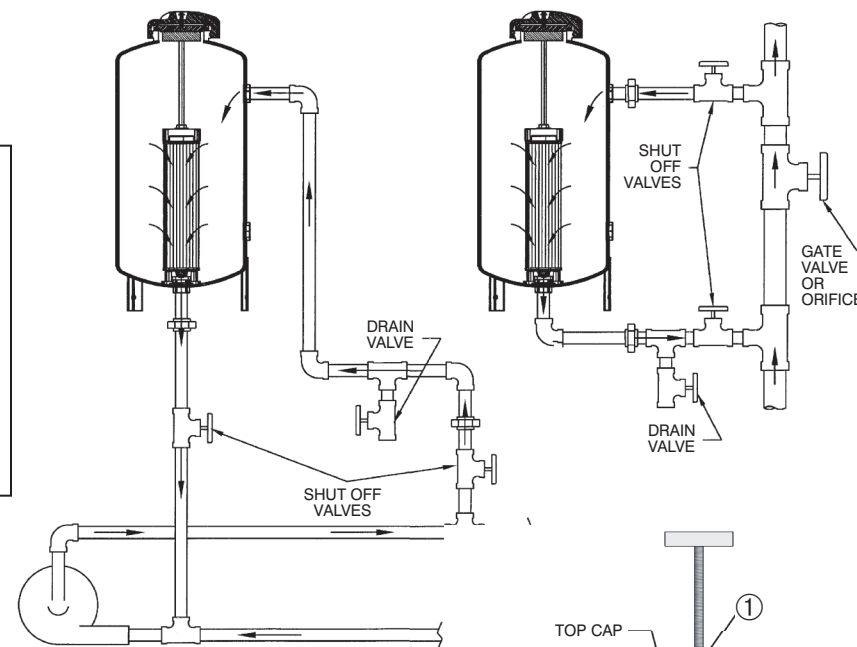

FILTER FEEDER ASSEMBLY INSTRUCTIONS

Neptune Filter Feeders may be used as a By-Pass Feeder with or without the basket. The basket may be used for handling granular chemical products. A filter bag may be placed in the basket allowing the feeder to also be used as a filter.

The filter bag is placed *inside* the basket. Bags are available in 1, 5, 20 and 50 micron ratings. The bag slides into the basket and the ring rests on the top rim of the basket.

The basket is then placed into the feeder and will hang from the support lip.

Reverse the procedure and insert a clean bag as needed.

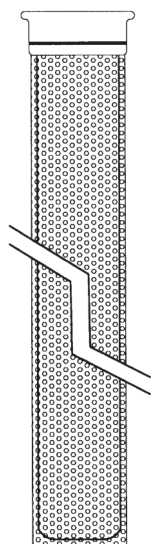

CARTRIDGE REMOVAL/REPLACEMENT INSTRUCTIONS

The cartridge filter assembly consists of two parts:

1. Handle Assembly
2. Filter Cartridge

Remove the cartridge filter assembly from the vessel by holding the handle (1) and pulling out straight. Loosen the jam nut just enough so that the threaded rod can be turned. (This will ensure the correct length of the handle-cartridge assembly to fit inside the vessel.) Unscrew threaded rod to separate bottom cap. Remove old cartridge (2) and discard. Slide a new cartridge (2) onto the top cap. Slide in the bottom cap. Screw in the threaded rod into the bottom cap until jam nut touches the top cap. Make sure that the ridge on the face of top and bottom caps line up with the grooves on the ends of the filter cartridge. Snug the jam nut to secure cartridge. Check the sealing ring inside the end of the bottom cap and replace if necessary. Slide the cartridge filter assembly back into the vessel, taking care that the bottom cap is piloted onto the stub in the bottom of the tank. Make certain assembly is fully seated. Replace the cap.

