

Bulk Container Mixers – Gear Drive Bung or Bracket Mount

Neptune Bulk Container Mixers allow mixing in semi-bulk shipping containers.

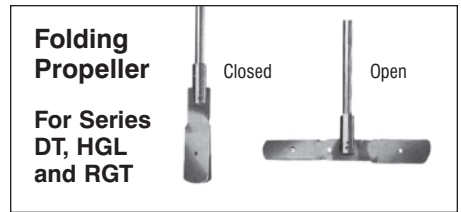

Series HGL, 430 rpm

Features

- Mounts to 2-in. coupling or flange.
- 316SS propeller folds to fit through 2-in. opening; opens to 9-in. operating diameter.
- Second folding propeller bolts anywhere on 3/4-in. shaft – part #004479.

Model Number	Standard Motor Description	Shaft Diameter
Totally-enclosed fan-cooled (TEFC)		
HGL-2.0	1/3 HP-1-115/230	3/4"
HGL-3.0	1/2 HP-1-115/230	3/4"
HGL-5.0	3/4 HP-1-115/230	3/4"
HGL-6.0	1 HP-1-115/230	3/4"
HGL-6.2	1 HP-3-230/460	3/4"
Air motor		
HGL-4.0	1/2 HP AIR Air Requirements: 20CFM at 40PSI	3/4"
HGL-7.0	3/4 HP to 1 HP AIR Air Requirements: 30-40CFM at 25-35PSI	3/4"

For Explosion-proof models, see price list.

Series RGT, 350 rpm

Features

- Mounts to the tank or optional bracket.
- 316SS propeller folds to fit through 2-in. opening; opens to 9-in. operating diameter.
- Second folding propeller bolts anywhere on 3/4-in. shaft – part #004479.

Model Number	Standard Motor Description	Shaft Diameter
Totally-enclosed fan-cooled (TEFC)		
RGT-1.0	1/2 HP-1-115/230	3/4"
RGT-1.2	1/2 HP-3-230/460	3/4"
RGT-2.0	3/4 HP-1-115/230	3/4"
RGT-2.2	3/4 HP-3-230/460	3/4"
RGT-3.0	1 HP-1-115/230	3/4"
RGT-3.2	1 HP-3-230/460	3/4"
Air motor		
RGT-1.4	1/2 HP AIR Air Requirements: 20CFM at 40PSI	3/4"
RGT-3.4	3/4 HP to 1 HP AIR Air Requirements: 30-40CFM at 25-35PSI	3/4"

For Explosion-proof models, see price list.

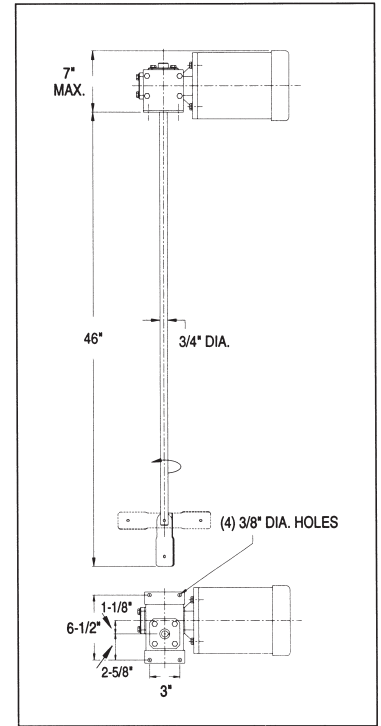

Use Series RGT Mixers on single containers or sandwich between stacked semi-bulk shipping containers.

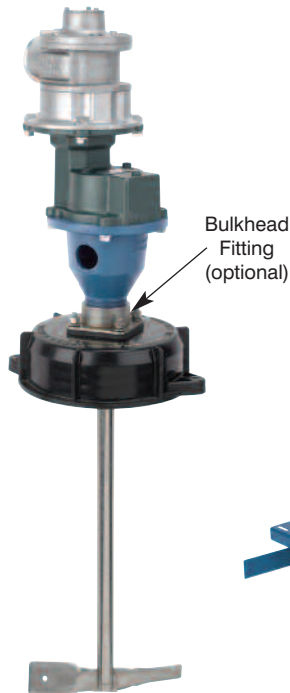
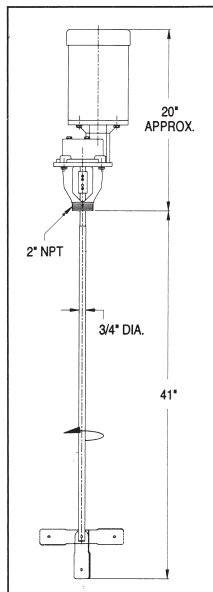

Series HGL Mixer with Cap Mount

Convert any poly cap to a 2-inch, SS, threaded, female fitting to mount the HGL mixer. Specify bulkhead fitting (optional), part #107739.

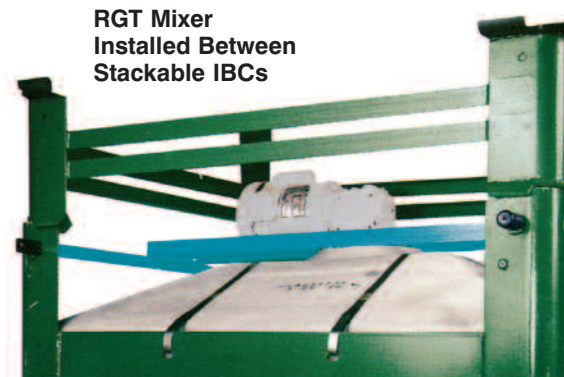

RGT Mixer Installed Between Stackable IBCs

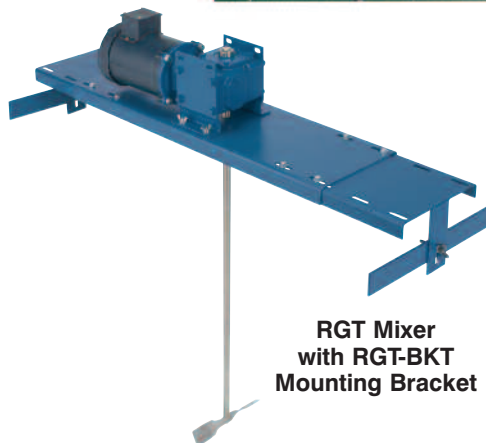

RGT Mixer with RGT-BKT Mounting Bracket

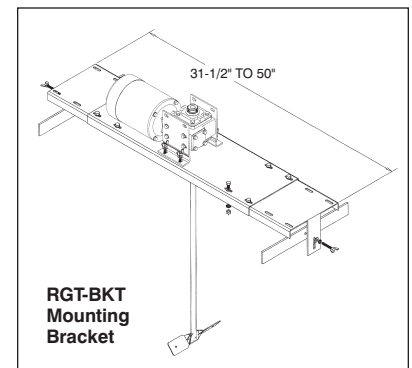

RGT-BKT Mounting Bracket